

(No Model.)

G. STRICKLAND.
LATHE SLIDE REST.

No. 507,047.

Patented Oct. 17, 1893.

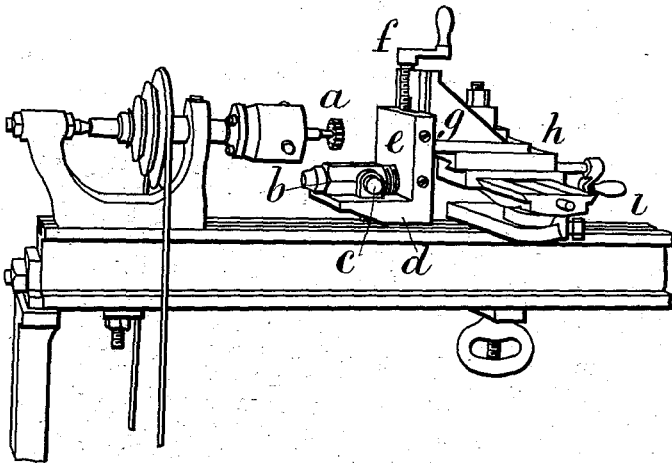

Witnesses:

J. H. Daly
Robert G. Nutt

Inventor:

Gerald Strickland

By *James L. Norris*
Att'y

UNITED STATES PATENT OFFICE.

GERALD STRICKLAND, OF VILLA BOLOGNA, ISLAND OF MALTA.

LATHE SLIDE-REST.

SPECIFICATION forming part of Letters Patent No. 507,047, dated October 17, 1893.

Application filed May 17, 1893. Serial No. 474,575. (No model.)

To all whom it may concern:

Be it known that I, GERALD STRICKLAND, Count della Catena, a citizen of Great Britain, residing at Villa Bologna, in the Island of Malta, have invented a new and useful Improvement in Lathe Slide-Rests, of which the following is a specification.

My invention relates to an appliance to the slide rest of a lathe by which I render it suitable for subjecting work in a convenient manner to the action of milling tools or revolving cutters, as I shall describe referring to the accompanying drawing, which shows in perspective the head, mandrel and slide rest of a lathe with my invention applied thereto.

a is a milling tool or revolving cutter.

b is a piece of work, such as a hexagonal nut for a ratchet brace, which is to be milled. In order to subject this work *b* to the action of the cutter *a*, I fix it by dogs *c*, or in any other known manner, on a horizontal shelf *d* projecting from a vertical slide *e* which is worked by a screw and handle *f*, and is held by a bracket *g* detachably bolted on to the upper of the two slides *h* and *i* of an ordinary

slide rest. By means of these slides I can move *b* longitudinally and transversely in the horizontal plane, while, by means of the detachably supported slide *e*, I can move it to or from the cutter *a* in the vertical plane.

Having thus described the nature of this invention and the best means I know of carrying the same into practical effect, I claim—

The combination with a milling tool and the horizontal slides *h* and *i*, of the bracket *g* detachably supported on the upper horizontal slide, and the vertically movable slide *e* attached to said bracket and having a horizontally projecting shelf *d* provided with dogs *c* for holding the work, substantially as shown and described.

In testimony whereof I have signed my name to this specification, in the presence of two subscribing witnesses, this 19th day of April, A. D. 1893.

GERALD STRICKLAND.

Witnesses:

J. DIBONS,
C. AGINS.